 Onderstaand assortimentsoverzicht geeft een indruk van de mogelijkheden van GNS Nederland. Gezien de enorme diversiteit aan afmetingen is enkel melding gemaakt van leverbare uitvoeringen en drukgroepen. De producten zijn leverbaar in DIN en ASME / ANSI kwaliteiten en desgewenst met certificaat volgens EN10204, aanvullende PMI tests e.d..

Bent u benieuwd naar de mogelijkheden? Schroom niet om ons te benaderen. We staan u graag te woord en willen graag met u meedenken over uw materiaal-behoefte. Onze mogelijkheden zullen u verrassen.

 Below mentioned program overview gives an impression of the possibilities of GNS. Given the enormous diversity in dimensions there is only mention made of available models and pressure classes. The products are available in DIN and ASME / ANSI qualities and optionally with certificates according to EN 10204, additional PMI tests etc.

Are you curious about the possibilities? Do not hesitate to contact us. We are always willing to help and would like to think along with you about your material needs. Our options will surprise you.

## Aluminium flenzen / Aluminium Flanschen / Aluminium flanges

<b>1: Vergelijkingstabel / Vergleichstabelle / comparison chart</b>	Page
1.1 <b>Buitenmaten inch / mm met schedule wanddikte afmetingen.</b> Außenmaßen inch / mm mit Schedule Wandstärken Outside dimensions inch / mm with schedule wall thicknesses	2
<b>2: Aluminium DIN / EN Flenzen   Aluminium DIN / EN Flanschen   Aluminium DIN / EN Flanges</b>	Page
2.1 <b>Voorlasflenzen / Vlakke lasflenzen / Overschuifflenzen / Blindflenzen / Draadflenzen</b> Vorschweißflanschen / Glatte Flanschen / Lose Flanschen / Blindflanschen / Gewindeflanschen Steel Welding neck flanges / Slip-On flanges / Lap-Joint flanges / Blindflanges / Threaded flanges	3
<b>3: Aluminium ASTM / ASME Flenzen   Alu ASTM / ASME Flanschen   Alu ASTM / ASME Flanges</b>	Page
3.1 <b>Voorlasflenzen / Vlakke lasflenzen / Overschuifflenzen / Blindflenzen / Draadflenzen</b> Vorschweißflanschen / Glatte Flanschen / Lose Flanschen / Blindflanschen / Gewindeflanschen Steel Welding neck flanges / Slip-On flanges / Lap-Joint flanges / Blindflanges / Threaded flanges	3



## 1 Overzichtstabel / Übersichtstabelle / Overview table

### 1.1 Aansluitmaten inch / mm met schedule wanddikte afmetingen.

Anschlußmaße inch / mm mit schedule Wandstärken.



Connection dimensions inch / mm with schedule wall thicknesses.

DN NW	NPS (inch)	EN / ISO (mm)	DIN (mm) *		ANSI ASME (mm)	Schedule (mm)													
			Reihe 1	Reihe 2		5	10	20	30	40(s)	60	80(s)	100	120	160	XXS			
6	1/8	10,2	10,2	-	10,29	0,89	1,24		1,45	1,73		2,41							
8	1/4	13,5	13,5	-	13,72	1,25	1,65		1,85	2,24		3,02							
10	3/8	17,2	17,2	14	17,14	1,24	1,65		1,85	2,31		3,20							
15	1/2	21,3	21,3	20	21,34	1,65	2,11		2,41	2,77		3,73			4,78	7,47			
20	3/4	26,9	26,9	25	26,67	1,65	2,11		2,41	2,87		3,91			5,56	7,82			
25	1	33,7	33,7	30	33,40	1,65	2,77		2,90	3,38		4,55			6,35	9,09			
32	1 1/4	42,4	42,4	38	42,16	1,65	2,77		2,97	3,56		4,85			6,35	9,70			
40	1 1/2	48,3	48,3	44,5	48,26	1,65	2,77		3,18	3,68		5,08			7,14	10,16			
50	2	60,3	60,3	57	60,33	1,65	2,77		3,18	3,91		5,54		6,35	8,74	11,07			
65	2 1/2	76,1	76,1	-	73,02	2,11	3,05		4,78	5,16		7,01		7,62	9,53	14,02			
80	3	88,9	88,9	-	88,90	2,11	3,05		4,78	5,49		7,62		8,89	11,13	15,24			
90	3 1/2	101,6	-	-	101,60	2,11	3,05		4,78	5,74		8,08			13,49	16,15			

DN NW	NPS (inch)	EN / ISO (mm)	DIN (mm) *		ANSI ASME (mm)	Schedule (mm)													
			Reihe 1	Reihe 2		5	10	20	30	40(s)	60	80(s)	100	120	140	160	XXS		
100	4	114,3	114,3	108	114,30	2,11	3,05		4,78	6,02	7,14	8,56		11,10		13,49	17,12		
115	4 1/2	-	-	-	127,00					6,27		9,02					18,03		
125	5	139,7	139,7	133	141,30	2,77	3,40			6,55		9,53		12,70		15,88	19,05		
150	6	168,3	168,3	159	168,28	2,77	3,40			7,11		10,97		14,28		18,26	21,95		
-	7	193,7	193,7	-	193,68					7,65		12,70					22,23		
200	8	219,1	219,1	-	219,08	2,77	3,76	6,35	7,04	8,18	10,31	12,70	15,06	18,26	20,63	23,01	22,23		
-	9	244,5	-	-	244,48					8,69		12,70							





DN NW	NPS (inch)	EN / ISO (mm)	DIN (mm) *		ANSI ASME (mm)	Schedule (mm)													
			Reihe 1	Reihe 2		5s	5	10	20	30	40s	40	60	80s	80	100	120	140	160
250	10	273	273	267	273,05	3,40	3,40	4,19	6,35	7,80	9,27	9,27	12,70	12,70	15,06	18,26	21,41	25,40	28,58
300	12	323,9	323,9	-	323,85	3,96	4,19	4,57	6,35	8,38	9,53	10,31	14,28	12,70	17,45	21,41	25,40	28,58	33,33
350	14	355,6	355,5	368	355,60	3,96	3,96	6,35	7,93	9,53	9,53	11,10	15,06	12,70	19,05	23,80	27,76	31,75	35,71
400	16	406,4	406,4	419	406,40	4,19	4,19	6,35	7,93	9,53	9,53	12,70	16,66	12,70	21,41	26,19	30,94	36,50	40,46
450	18	457,2	457,2	-	457,20	4,19	4,19	6,35	7,93	11,10	9,53	14,28	19,05	12,70	23,80	29,36	34,93	39,68	45,24
500	20	508	508	-	508,00	4,78	6,35	6,35	9,53	12,70	9,53	15,06	20,63	12,70	26,19	32,51	38,10	44,45	49,99
550	22	558,8	-	-	558,80	4,78	6,35	6,35	9,53	12,70	9,53		22,23	12,70	28,58	34,93	41,28	47,63	53,98
600	24	609,6	609,8	-	609,60	5,54	5,54	6,35	9,53	14,28	9,53	17,45	24,59	12,70	30,94	38,89	46,03	52,38	59,51

DN NW	NPS (inch)	EN / ISO (mm)	DIN (mm) *		ANSI ASME (mm)	Schedule (mm)													
			Reihe 1	Reihe 2		5s	10s	10	20	30	40s	40							
650	26	660,4	-	-	660,40			7,93	12,70	9,53		12,70							
700	28	711,2	711,2	-	711,20			7,93	12,70	15,88	9,53								
750	30	762,0	-	-	762,00	6,35	7,93	7,93	12,70	15,88	9,53								
800	32	812,8	812,8	-	812,80			7,93	12,70	15,88	9,53	17,48							
850	34	863,6	-	-	863,60			7,93	12,70	15,88	9,53	17,48							
900	36	914,4	914,4	-	914,40			7,93		15,88	9,53	19,05							

- \*  Aansluitmaten volgens *Reihe 1* zijn gelijk aan EN / ISO m.u.v. -. Aansluitmaten volgens *Reihe 2* zijn afwijkend van EN / ISO.
- \*  Anschlußmaße nach *Reihe 1* sind ähnlich EN / ISO außer -. Anschlußmaße nach *Reihe 2* sind abweichend von EN / ISO.
- \*  Connection dimensions acc. *Reihe 1* are similar to EN / ISO with exception of -. Connection dimensions acc. *Reihe 2* are different from EN / ISO.



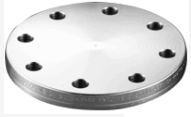
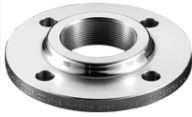



## 2.1 Aluminium DIN / EN Flenzen | DIN / EN Flanschen | DIN / EN Flanges EN AW 1050/5754

	2.1.1	2.1.2	2.1.3	2.1.4	2.1.5
					
	<b>Voorlasflens</b> Vorschweißflansche Welding neck flange	<b>Vlakke lasflens</b> Glatte Flansche Slip-On flange	<b>Overschuifflens</b> Lose Flanche Lap-Joint flange	<b>Blindflens</b> Blindflansche Blindflange	<b>Draadflens</b> Gewindeflansche Threaded flange
	<b>Typen/Typen/Types</b> ≈DIN 2632 PN 10 ≈(EN 1092-1) type 11	<b>Typen/Typen/Types</b> ≈DIN 2576 PN 10 ≈(EN 1092-1) type 1	<b>Typen/Typen/Types</b> ≈DIN 2642 PN 10 ≈(EN 1092-1) type 2	<b>Typen/Typen/Types</b> ≈DIN 2527 PN 10 ≈(EN 1092-1) type 5	<b>Typen/Typen/Types</b> ≈DIN 2566 PN 10 ≈(EN 1092-1) type 13
	≈DIN 2633 PN 16 ≈(EN 1092-1) type 11	≈DIN 2576 PN 16 ≈(EN 1092-1) type 1	≈DIN 2642 PN 16 ≈(EN 1092-1) type 2	≈DIN 2527 PN 16 ≈(EN 1092-1) type 5	≈DIN 2566 PN 16 ≈(EN 1092-1) type 13
	≈DIN 2635 PN 40 ≈(EN 1092-1) type 11	≈DIN 2576 PN 40 ≈(EN 1092-1) type 1	≈DIN 2656 PN 40 ≈(EN 1092-1) type 2	≈DIN 2527 PN 40 ≈(EN 1092-1) type 5	≈DIN 2567 PN 40 ≈(EN 1092-1) type 13

Afwijkende drukgroepen en/ of kwaliteiten op aanvraag / Different pressure classes and/ or qualities on request

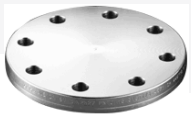
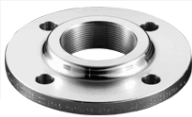
## 3.1 Aluminium ASTM / ASME Flenzen | ASTM / ASME Flanschen | ASTM / ASME Flanges

	3.1.1	3.1.2	3.1.3	3.1.4	3.1.5
					
	<b>Voorlasflens</b> Vorschweißflansche Welding neck flange	<b>Vlakke lasflens</b> Glatte Flansche Slip-On flange	<b>Overschuifflens</b> Lose Flanche Lap-Joint flange	<b>Blindflens</b> Blindflansche Blindflange	<b>Draadflens</b> Gewindeflansche Threaded flange
	<b>Typen/Typen/Types</b> ≈ASTM B247 ≈ASME B16.5 5083 / 5086 / 6061	<b>Typen/Typen/Types</b> ≈ASTM B247 ≈ASME B16.5 5083 / 5086 / 6061	<b>Typen/Typen/Types</b> ≈ASTM B247 ≈ASME B16.5 5083 / 5086 / 6061	<b>Typen/Typen/Types</b> ≈ASTM B247 ≈ASME B16.5 5083 / 5086 / 6061	<b>Typen/Typen/Types</b> ≈ASTM B247 ≈ASME B16.5 5083 / 5086 / 6061

Drukgroepen op aanvraag / Pressure classes on request